

GREAT FUN WITH TINY ML

PÄR-ANTON WESTBOM

CADEC 2023.01.19 & 2023.01.25 | CALLISTAENTERPRISE.SE

CALLISTA

AGENDA

- What is TinyML (Tiny Machine Learning)
- Demo
- Conclusion

WHAT IS TINYML (TinyMachineLearning)

- Tiny refer to the device size that does the computation. Typically different sensors (camera, microphone, gyroscope, thermometer, bloodpressure, ...) aka IoT devices
- ML stands for Machine Learning
- What makes it interesting
 - It is possible
 - There are open source initiatives to be used
 - It solves or helps with some challenges with today's approaches.

AN EXAMPLE OF TINYML TODAY

- Mobile wake up call

Hey Siri

Hey Alexa

Hey Google

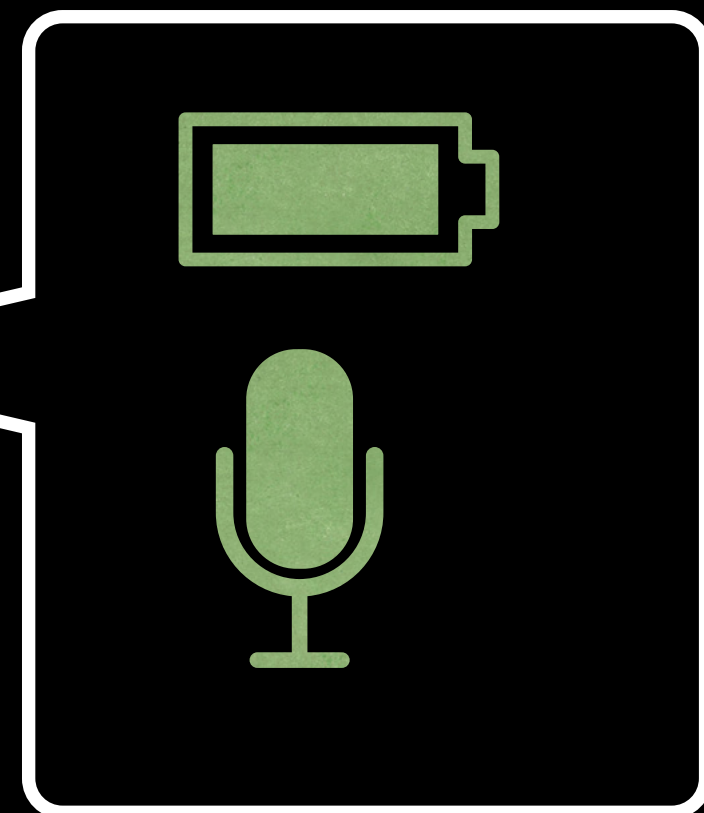

A circuit with speech recognition by itself.
1 mW = CR2032 for a year

HOME AUTOMATION EXAMPLE

TODAY

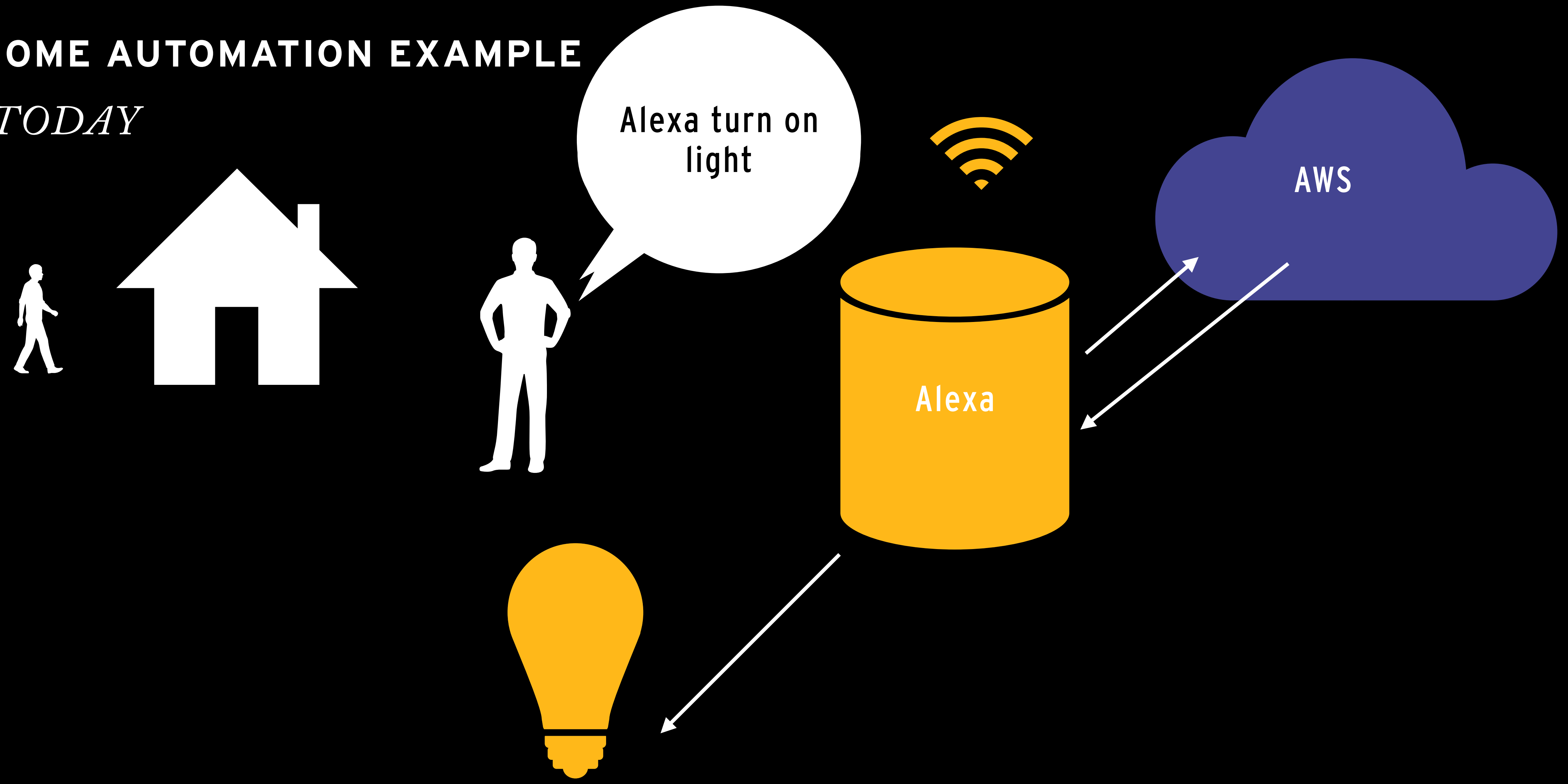

TODAY MOST DEVICES TODAY HAVE A CENTRAL APPROACH

- The traditional idea of IoT was to send data from a local device to the cloud for processing.
- There are some problems doing it this way

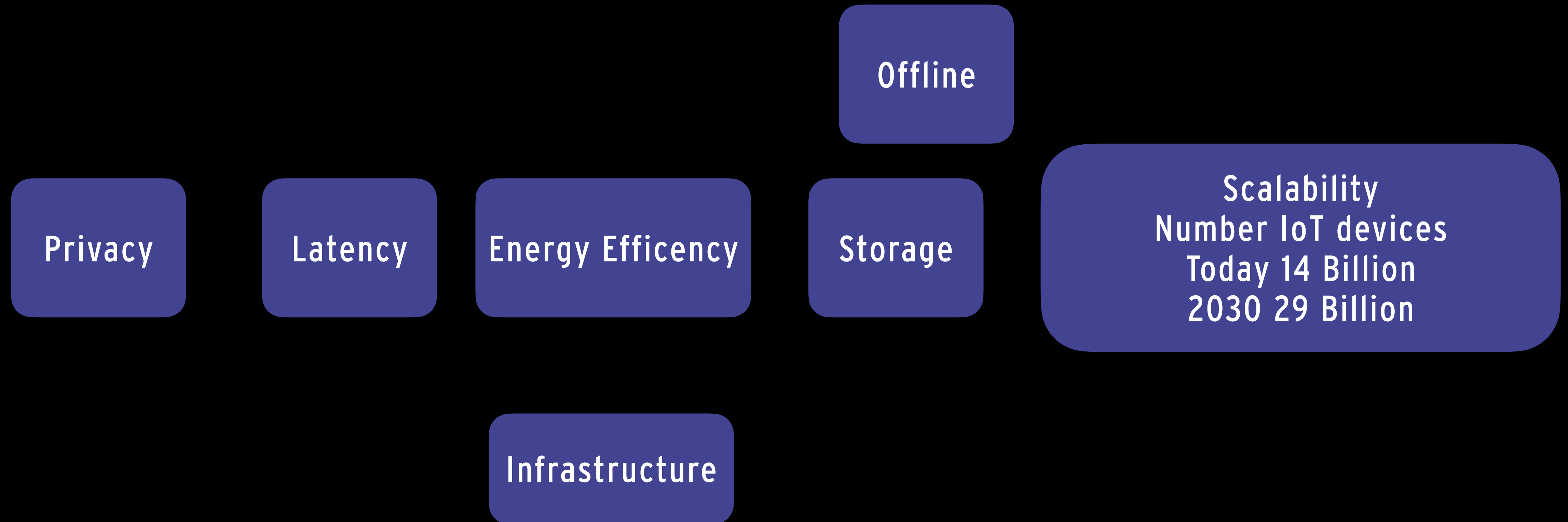

HOME AUTOMATION EXAMPLE *DISTRIBUTED APPROACH*

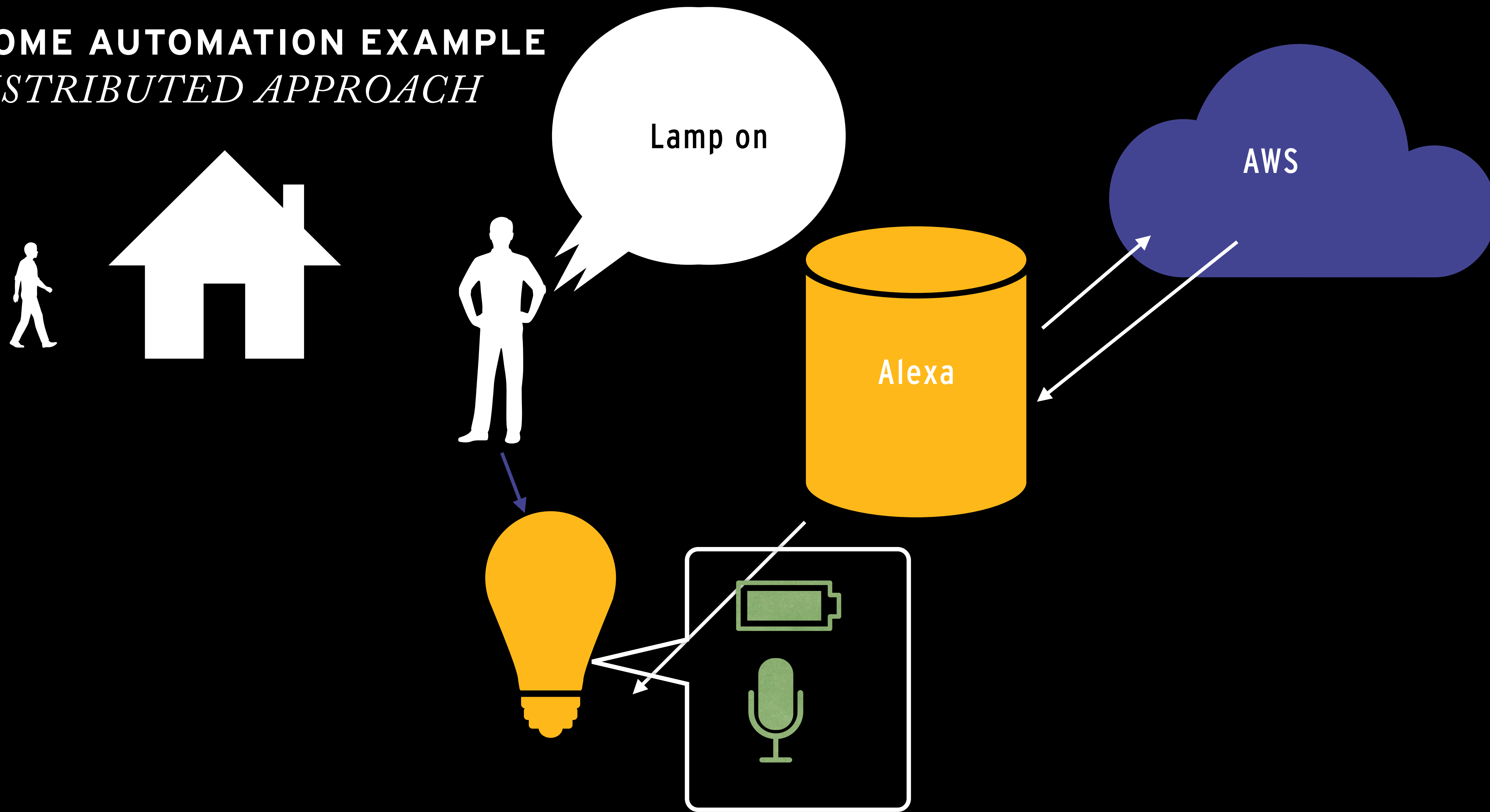

■ THERMAL CAMERAS

- Animal detection
- Human detection
- Traffic
- Privacy
-



<https://www.weforum.org/agenda/2021/03/human-elephant-conflict-camera-solution-zsl/>

HUMAN ELEPHANT CONFLICT (HEC)



<https://www.weforum.org/agenda/2021/03/>

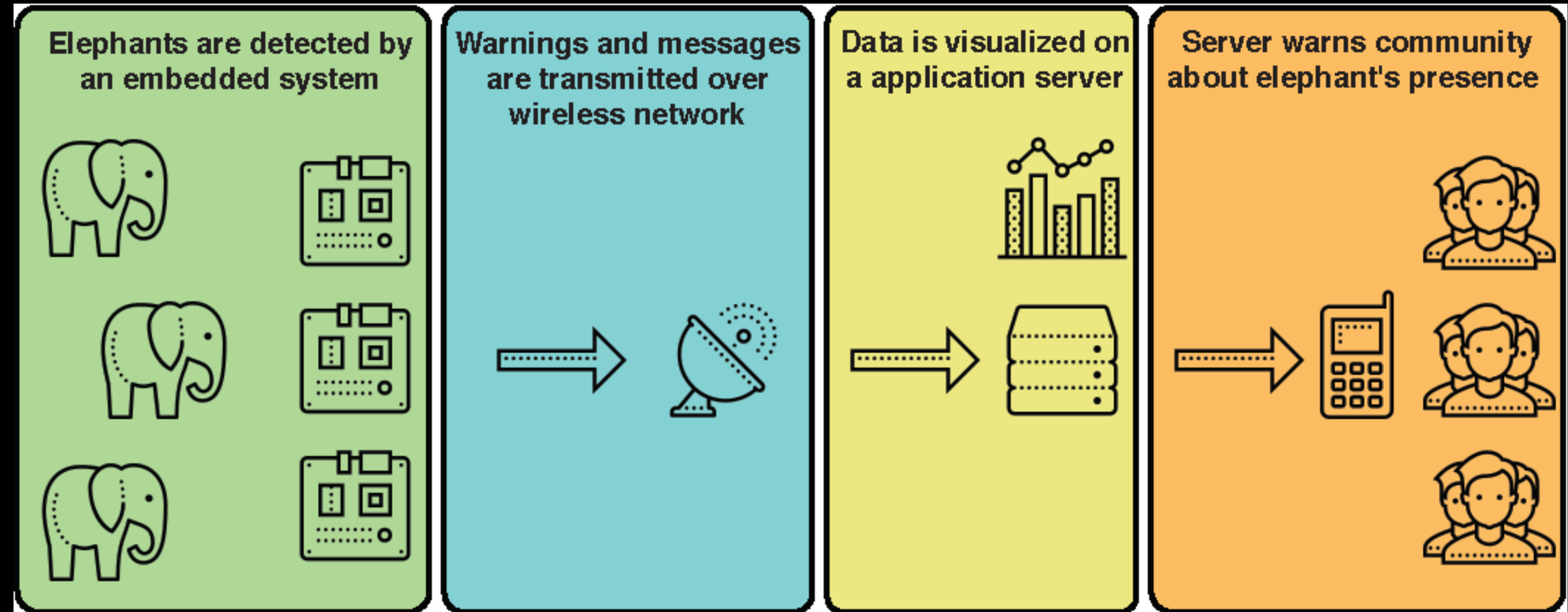

<https://www.irnas.eu/energy-efficient-system-for-detection-of-elephants-with-machine-learning/>

■ THERMAL CAMERAS

- Animal detection
- Human detection
- Traffic
- Privacy
-



<https://www.weforum.org/agenda/2021/03/human-elephant-conflict-camera-solution-zsl/>

PROS DOING MORE THING ON THE DEVICE (DISTRIBUTED APPROACH)

- Energy Efficient it cost less energy to have an IoT device do its own computation. Transmitting raw data is energy intensive.
- Privacy & Security Keeping data on the device.
- Storage only keep data that are of interest.
- Latency
- Connectivity
- Infrastructure
- ...

CHALLENGES

CHALLENGES DOING COMPUTATION AS PROCESSING ML MODELS ON SMALL DEVICES

- **Memory (Low)** 1MB Flash, 256 KB Ram
- **Power (Limited)** 3.3 V
- **Processing Power (Limited)** 64 Mhz
- **Troubleshooting** and updating of the software when distributed

TENSORFLOW LITE (2017) (OVER 2 BILLION DEVICES IN 2019)



TensorFlow Lite



PYTORCH MOBILE

1. Tensorflow trains the model
2. Tensorflow Lite
 1. Convert the model
 2. Optimize the model
 3. A model that can be deployed to (Microcontrollers, Linux Embedded devices, Android, iOS)

THE STAGE IS SET FOR THE DEMO(S)

- We have set the context for TinyML and what it is all about. Let's explore the field practical.

In this experiment

- Arduino 33 BLE Sense
- Released Autumn 2019
- 1 MB Flash, 256 KB Ram, 3.3 V
- 64 Mhz Nina-b3
- 18 x 45 mm (Like an EarPod)
- Temp, pressure, microphone ...
Gesture Sensor, BLE (BlueTooth)
- All about gestures this time

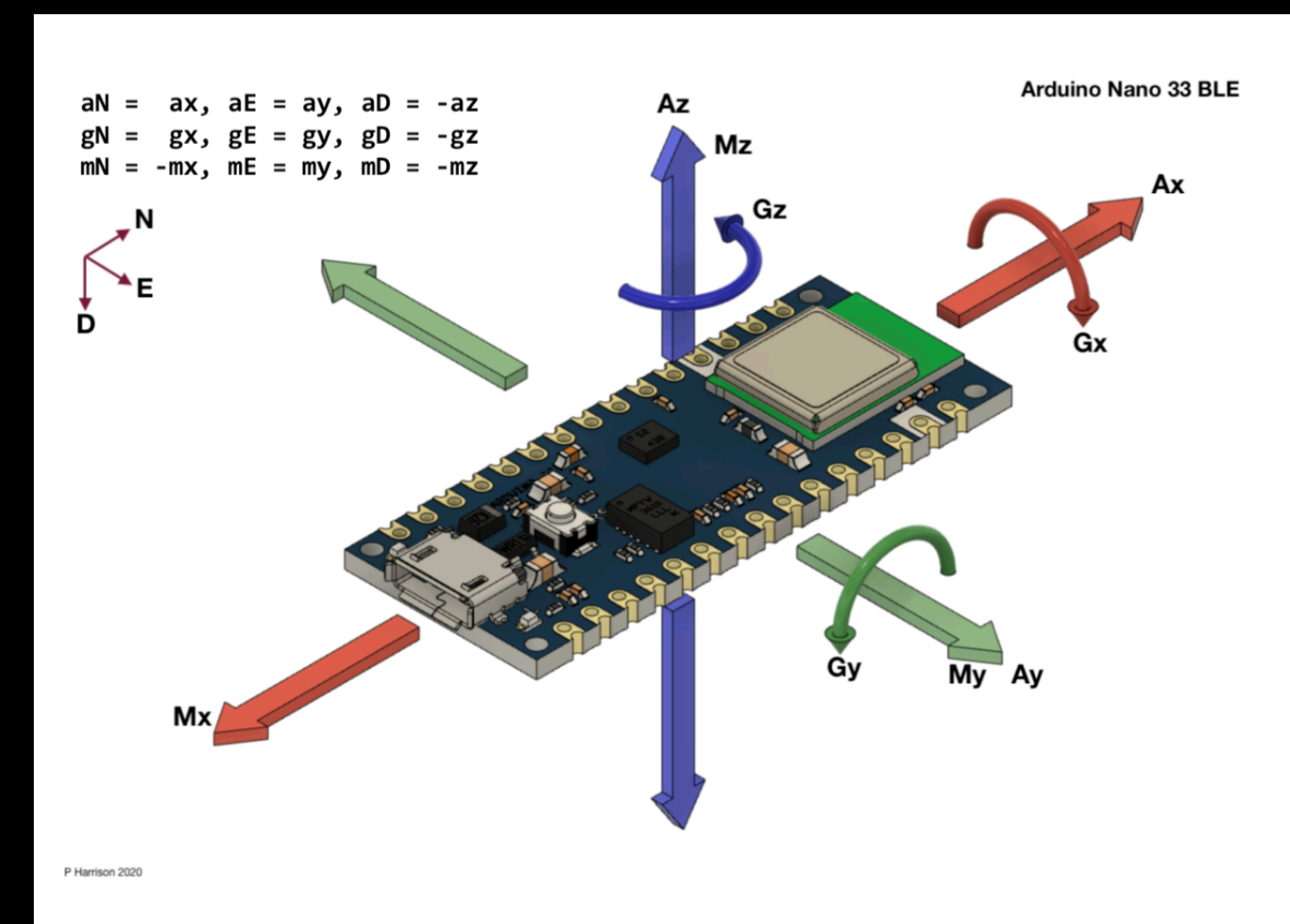

TINY MOTION TRAINER (TMT) BY GOOGLE CREATIVE LABS



- Tiny Motion Trainer is a part of the TensorFlow Lite for Microcontrollers Experiments, a collection of open source interactive projects designed to demonstrate some fun ways to combine Arduino (the microcontroller) and TensorFlow Lite for microcontrollers.
- Projects using Tiny Motion trainer are build with Arduino Sense 33 BLE, TensorFlow Lite for microcontrollers and standard web technologies.
- <https://github.com/googlecreativelab/tiny-motion-trainer>

This is what we are going to try now!

■ FIRST STEP

- Before the Arduino has been setup to work with Tiny Motion Trainer (TMT) (Gyro, BlueTooth, TMT-lib)
- Connect our Arduino to (TMT)
- Collect data from the gyroscope to TMT
- Let TMT train a model on the data
- Download the trained model to our laptop

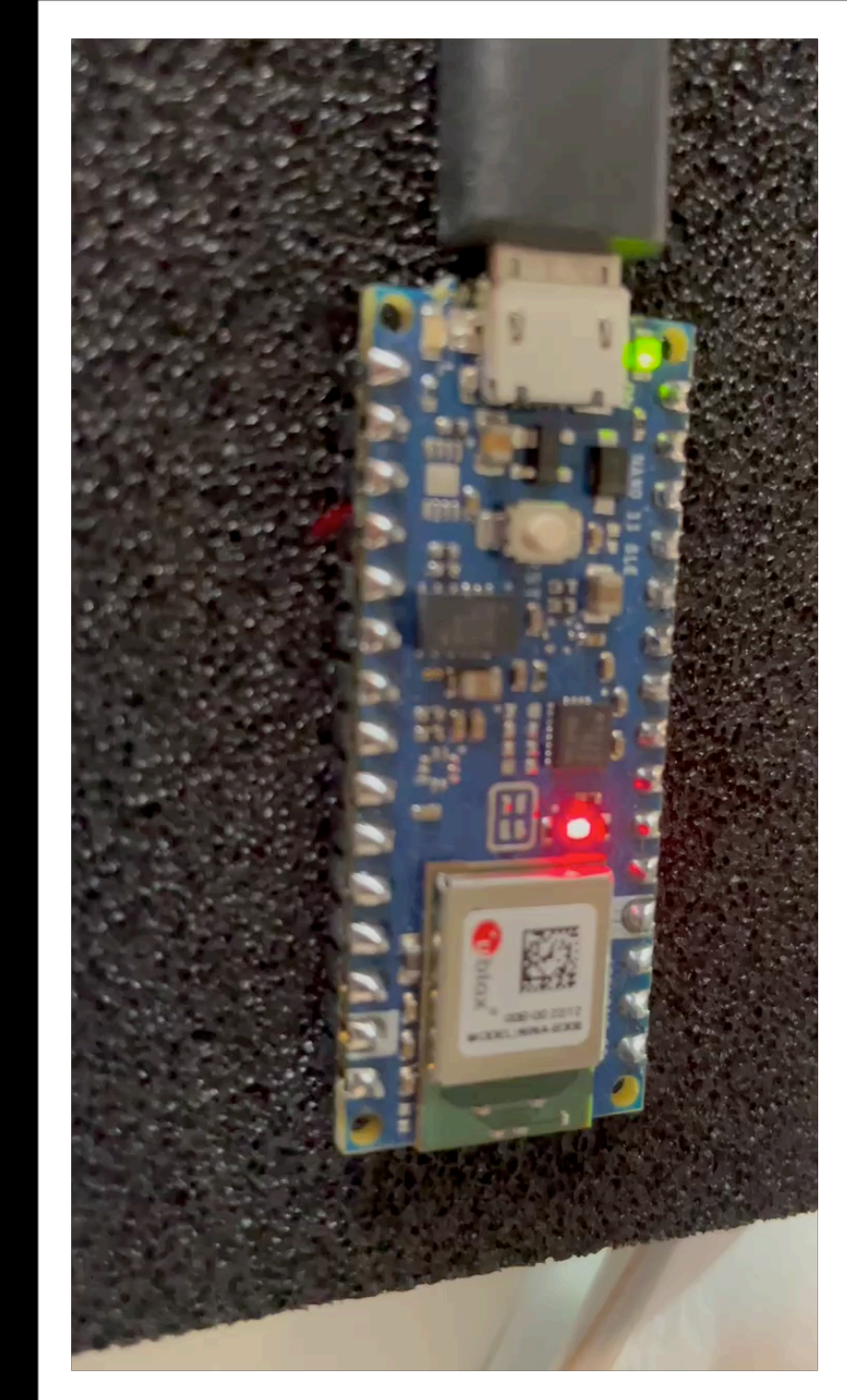

Experiment

COLLECT DATA

[HTTPS://EXPERIMENTS.WITHGOOGLE.COM/TINY-MOTION-TRAINER/VIEW/](https://experiments.withgoogle.com/tiny-motion-trainer/view/)

COLLECTED DATA (ACCELEROMETER AND GYROSCOPE)

WAVE

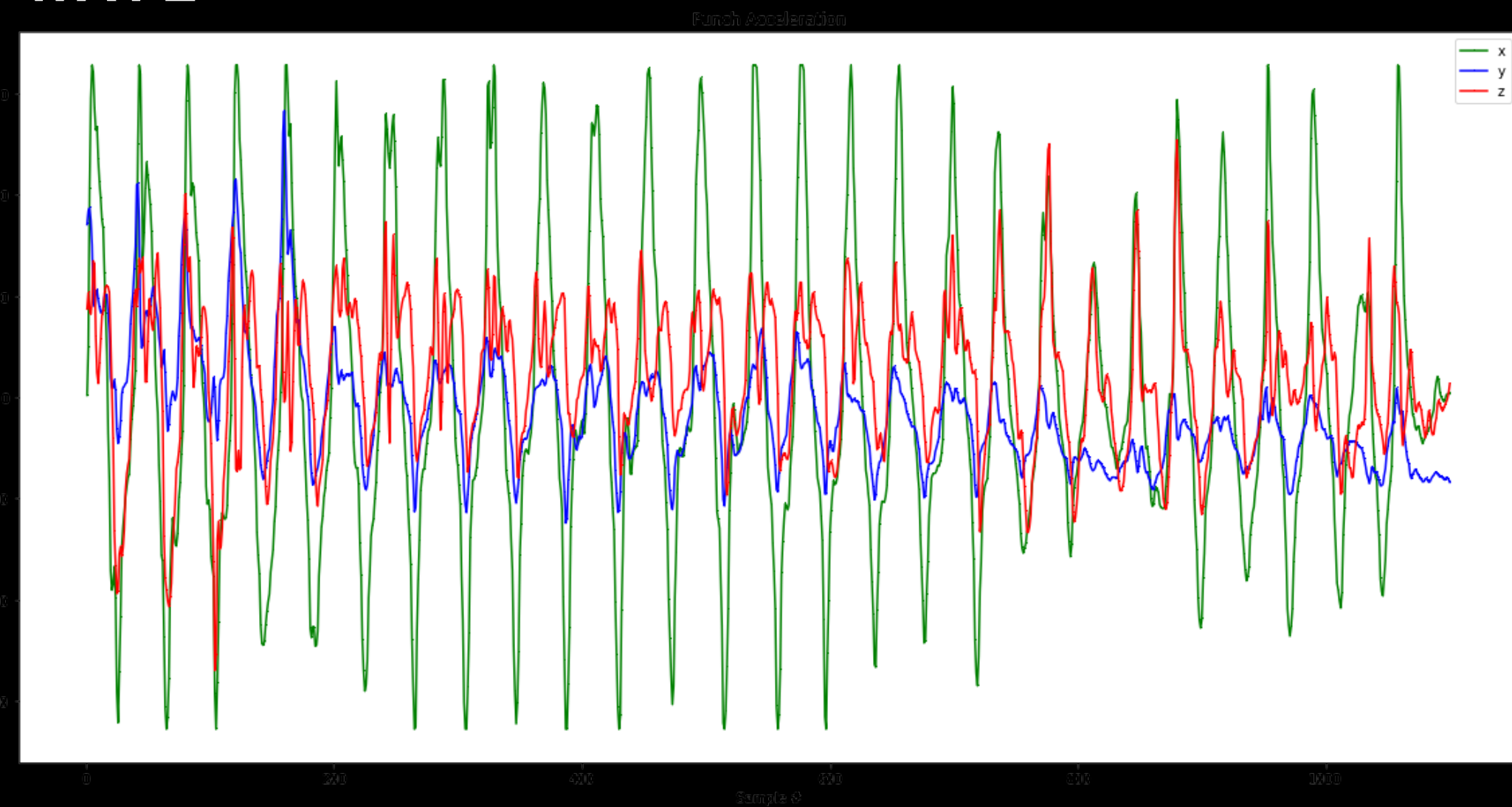

WAVE

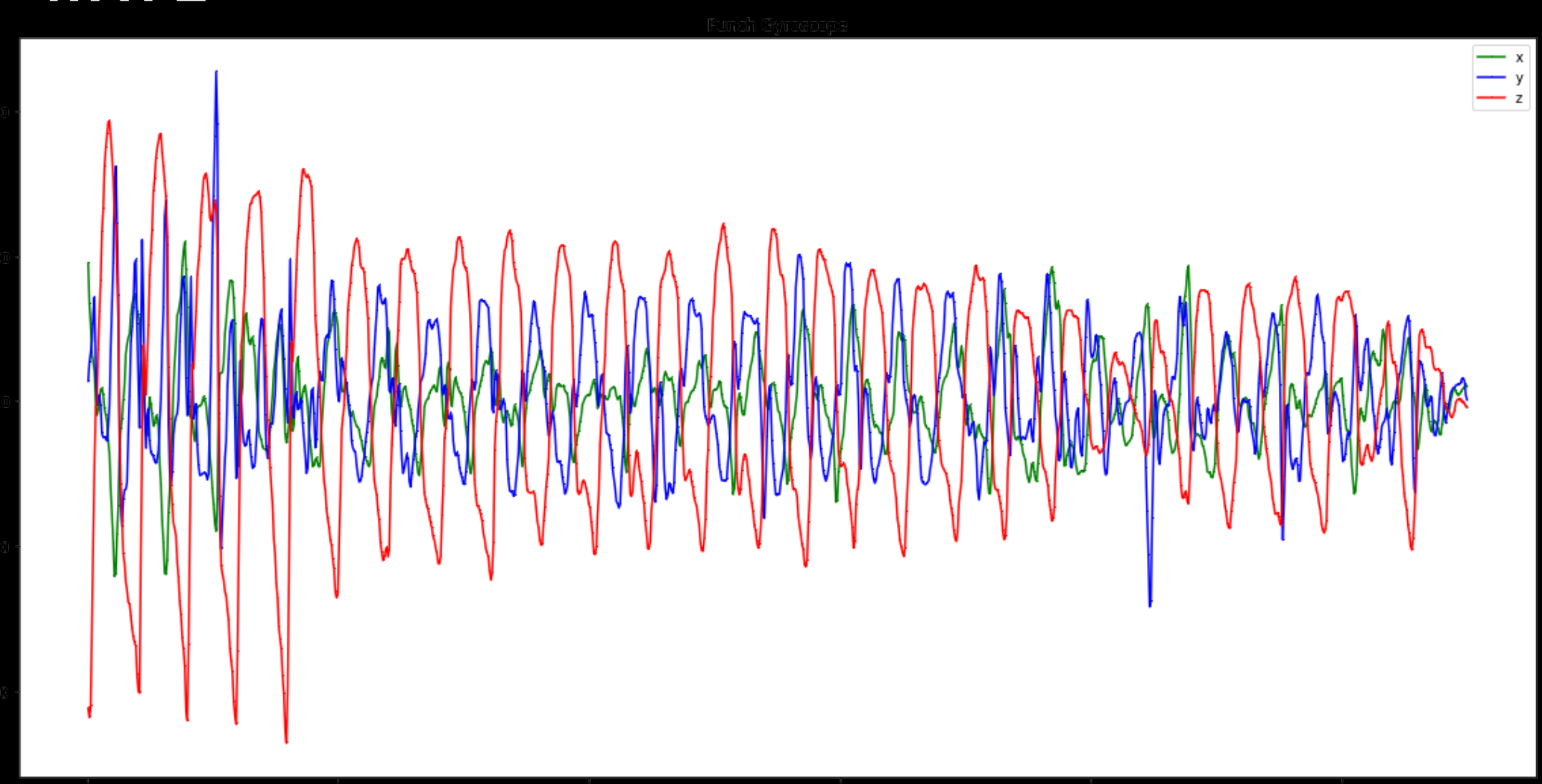

PUNCH

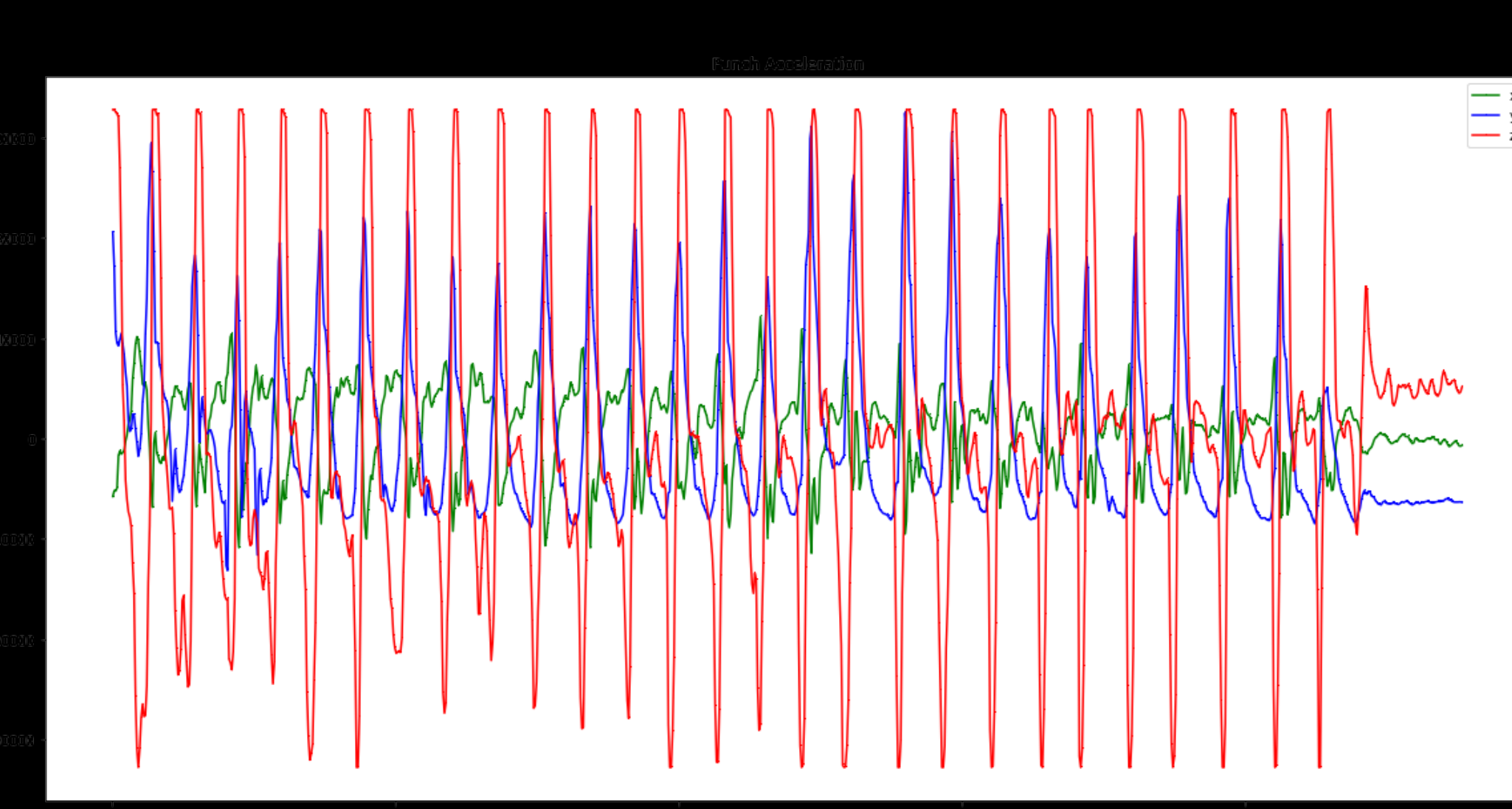

PUNCH

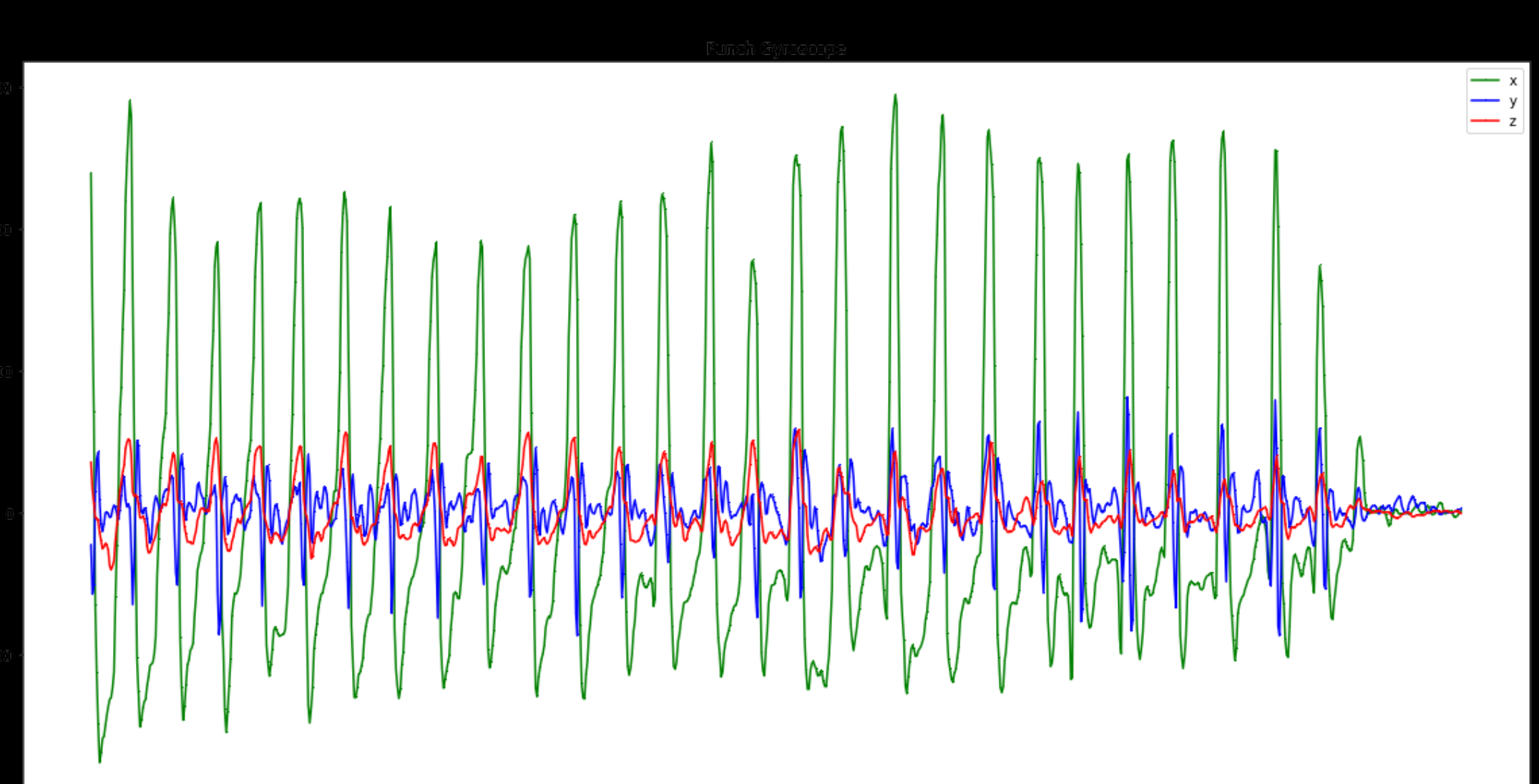

NEXT STEP

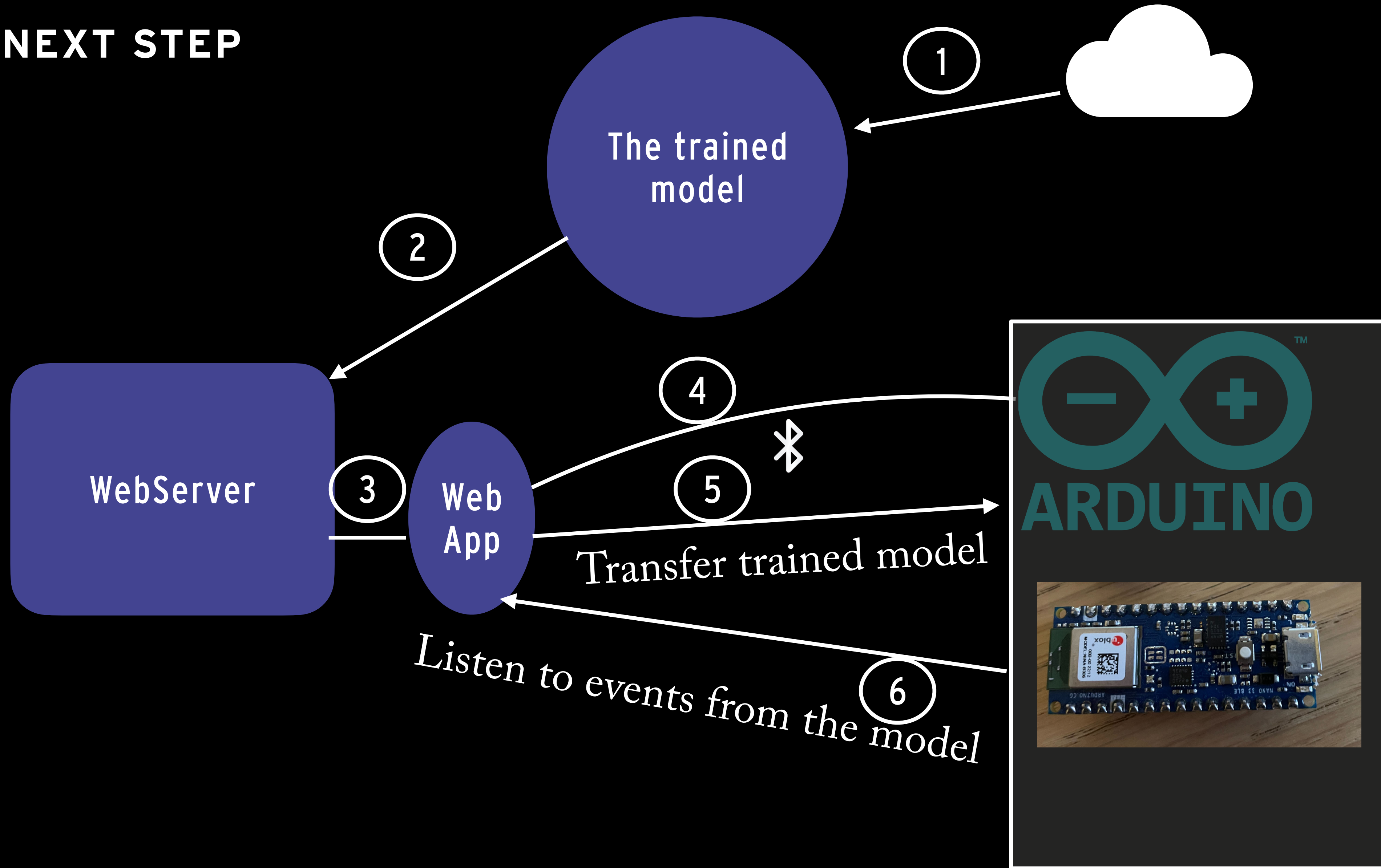

Fun With Machine Learning

Lets see if we can detect the motion we recorded.

Connect via Bluetooth and transfer tensorflow lite model

Click the button below, then select "TF4Micro Motion Kit" from the dialogue box.

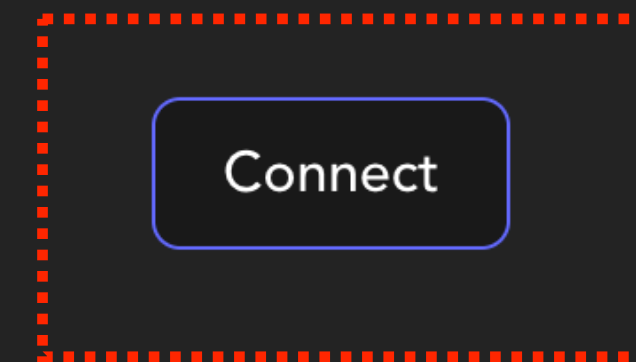

CONNECT BUTTON.JS

```
import connectButton from "tf4micro-motion-kit/web/button";
```

```
onMount(() => {  
  button = connectButton(containerEl, {  
    model: `./model.tflite?cache-bust=${Math.floor(  
      Math.random() * 1000000000  
    )}` ,  
    onInference(data){  
      $lastInference = data;  
    },  
  });  
});
```

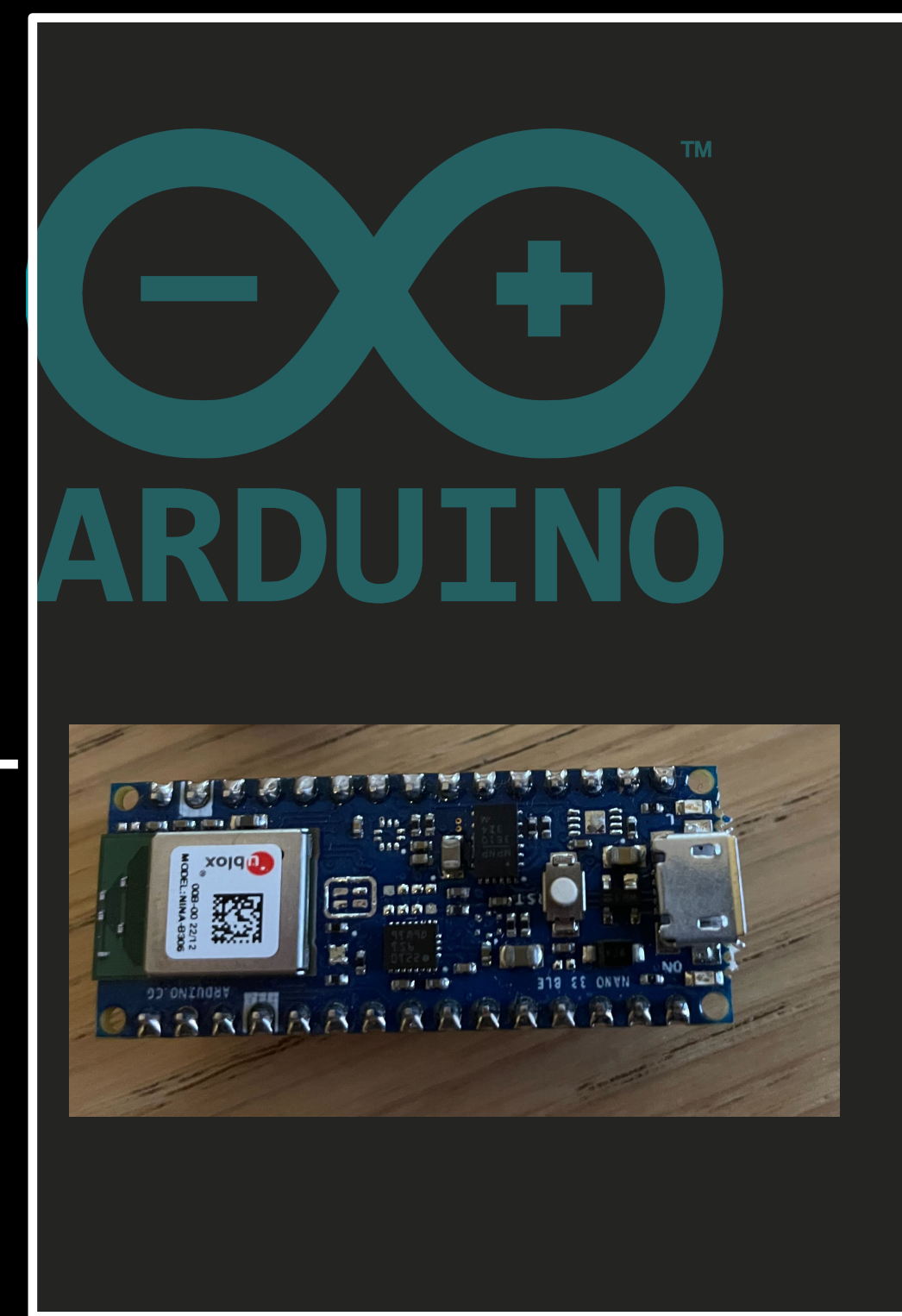
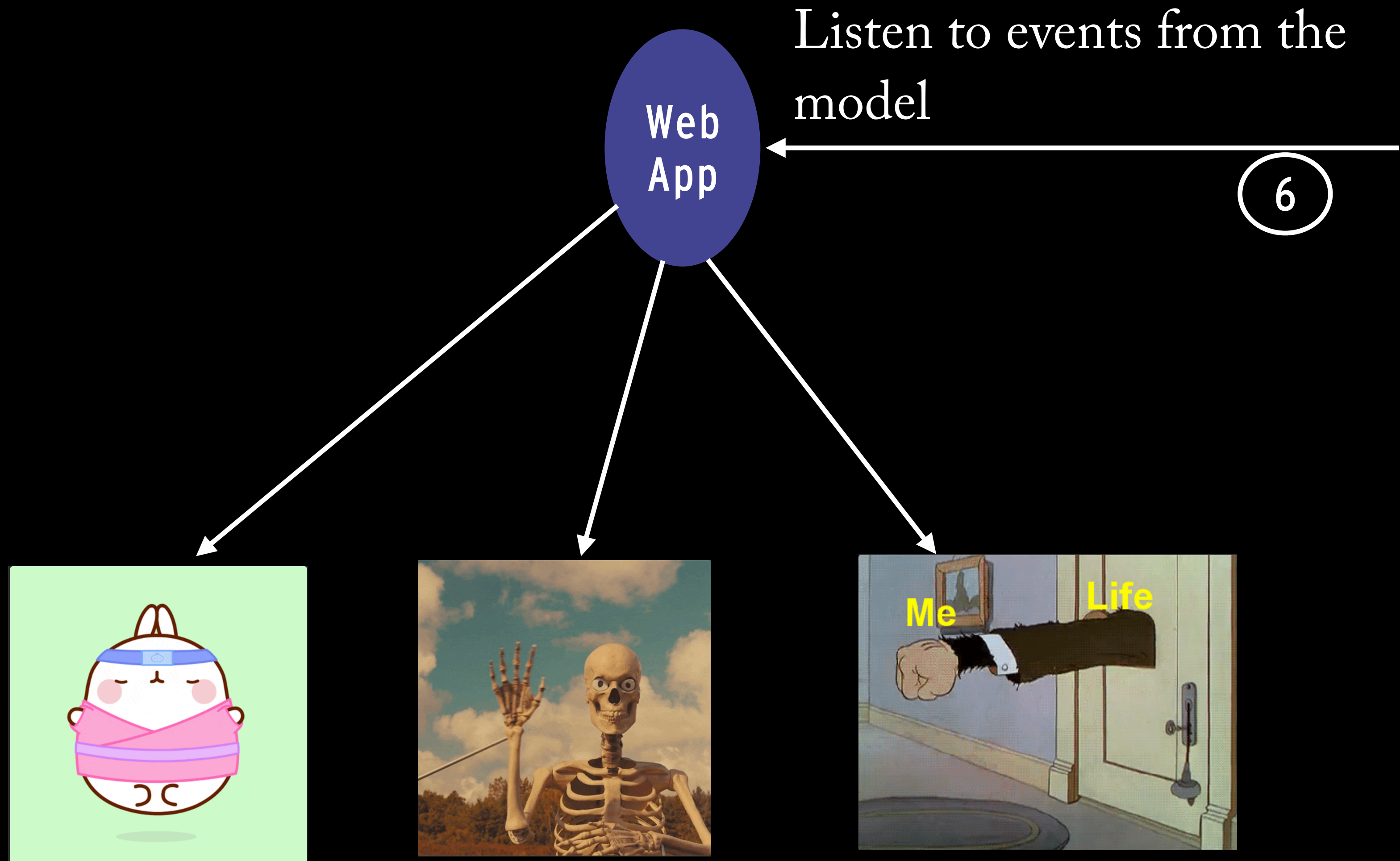

EXERCISE PANEL.JS

```
$: if ($lastInference) {  
  handleInference($lastInference);  
}  
  
function handleInference(data) {  
  noUpdate = false;  
  const index = data.index;  
  if (data.index === 0) {  
    // Wave to the crowd  
    numberOfWaves++;  
    exerciseImageSource = "./images/wavegiphy.gif";  
    activeExercise = "wave";  
  }  
  if (data.index === 1) {  
    //This is the punch  
    numberOfPunches++;  
    exerciseImageSource = "./images/punchgiphy.gif";  
    activeExercise = "punch";  
  }  
  lastExerciseScore = data.score;  
  exerciseScore = exerciseScore + (data.score ? data.score : 0);  
}
```

Let's do it

Experiment done

In our experiment one step missing, and that is that still all the training is done on a more powerful device

- TensorFlow Lite states (<https://www.tensorflow.org/lite/guide>)
 - Unsupported on-device training, however it is on our Roadmap



REFERENCES

- <https://www.tensorflow.org/lite/guide>
- <https://experiments.withgoogle.com/tiny-motion-trainer>
- <https://store.arduino.cc/products/arduino-nano-33-ble-sense>
- <https://www.techtarget.com/searchenterpriseai/feature/Why-TinyML-use-cases-are-taking-off>
- <https://www.irnas.eu/energy-efficient-system-for-detection-of-elephants-with-machine-learning/>
- All gifs shown was from <https://giphy.com/>

Bonus Demo